

Green Multicore Computing: Low Power High Performance



Hironori Kasahara, Ph.D., IEEE Fellow:

IEEE Computer Society President 2018

Professor, Dept. of Computer Science & Engineering

Director, Advanced Multicore Processor Research Institute

Senior Executive VP, Waseda University, Japan

URL: <http://www.kasahara.cs.waseda.ac.jp/>

1980 BS, 82 MS, 85 Ph.D. , Dept. EE, Waseda Univ.
1985 Visiting Scholar: U. of California, Berkeley,
1986 Assistant Prof., 1988 Associate Prof., 1989-90
Research Scholar:U. of Illinois, Urbana-Champaign,
Center for Supercomputing R&D, 1997 Prof., 2004
Director, Advanced Multicore Research Institute,
2017 member: the Engineering Academy of Japan
and the Science Council of Japan
2018 Nov. Senior Vice President, Waseda Univ.

1987 IFAC World Congress Young Author Prize
1997 IPSJ Sakai Special Research Award
2005 STARC Academia-Industry Research Award
2008 LSI of the Year Second Prize
2008 Intel AsiaAcademic Forum Best Research Award
2010 IEEE CS Golden Core Member Award
2014 Minister of Edu., Sci. & Tech. Research Prize
2015 IPSJ Fellow, 2017 IEEE Fellow, Eta Kappa Nu

Reviewed Papers: 216, Invited Talks: 162, Granted
Patents: 43 (Japan, US, GB, China), Articles in News
Papers, Web News, Medias incl. TV etc.: 584

Committees in Societies and Government 255
IEEE Computer Society: President 2018, BoG(2009-
14), Executive Committee(2017-), Multicore STC
Chair (2012-), Japan Chair(2005-07),
IPSJ Chair: HG for Magazine. & J. Edit, Sig. on ARC.
【METI/NEDO】 Project Leaders: Multicore for
Consumer Electronics, Advanced Parallelizing
Compiler, Chair: Computer Strategy Committee
【Cabinet Office】 CSTP Supercomputer Strategic
ICT PT, Japan Prize Selection Committees, etc.
【MEXT】 Info. Sci. & Tech. Committee,
Supercomputers (Earth Simulator, HPCI Promo.,
Next Gen. Supercomputer K) Committees, etc.

Multicores for Performance and Low Power

Power consumption is one of the biggest problems for performance scaling from smartphones to cloud servers and supercomputers (“K” more than 10MW) .

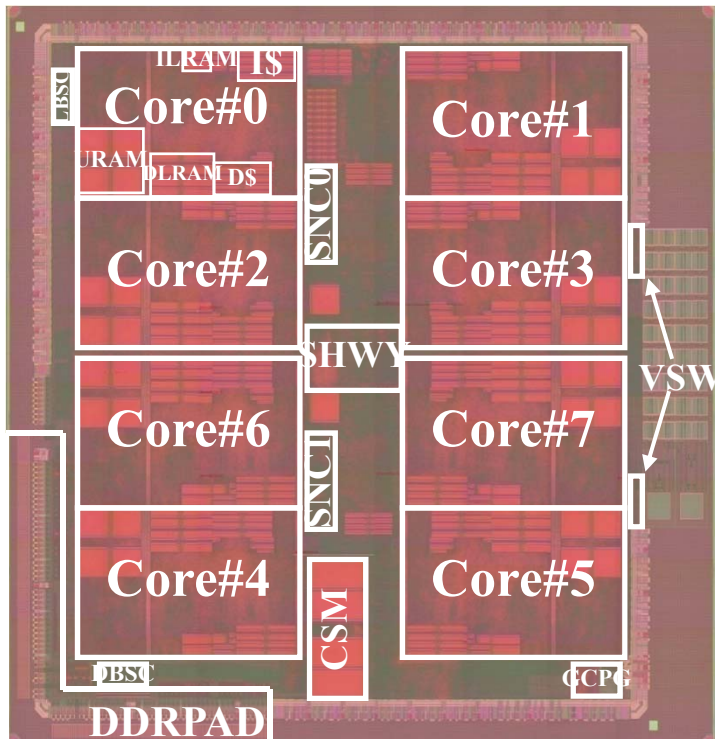

IEEE ISSCC08: Paper No. 4.5,
M.ITO, ... and H. Kasahara,
“An 8640 MIPS SoC with
Independent Power-off Control of 8
CPUs and 8 RAMs by an Automatic
Parallelizing Compiler”

Power \propto Frequency * Voltage²
(Voltage \propto Frequency)

➔ Power \propto Frequency³

If Frequency is reduced to 1/4
(Ex. 4GHz \rightarrow 1GHz),
Power is reduced to 1/64 and
Performance falls down to 1/4 .

<Multicores>

If 8cores are integrated on a chip,
Power is still 1/8 and
Performance becomes 2 times .

Parallel Soft is important for scalable performance of multicore (LCPC2015)

- Just more cores don't give us speedup
- Development cost and period of parallel software are getting a bottleneck of development of embedded systems, eg. IoT, Automobile

Earthquake wave propagation simulation GMS developed by National Research Institute for Earth Science and Disaster Resilience (NIED)

■ original (sun studio) ■ proposed method

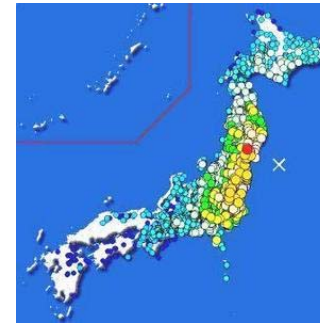

Fujitsu M9000 SPARC Multicore Server

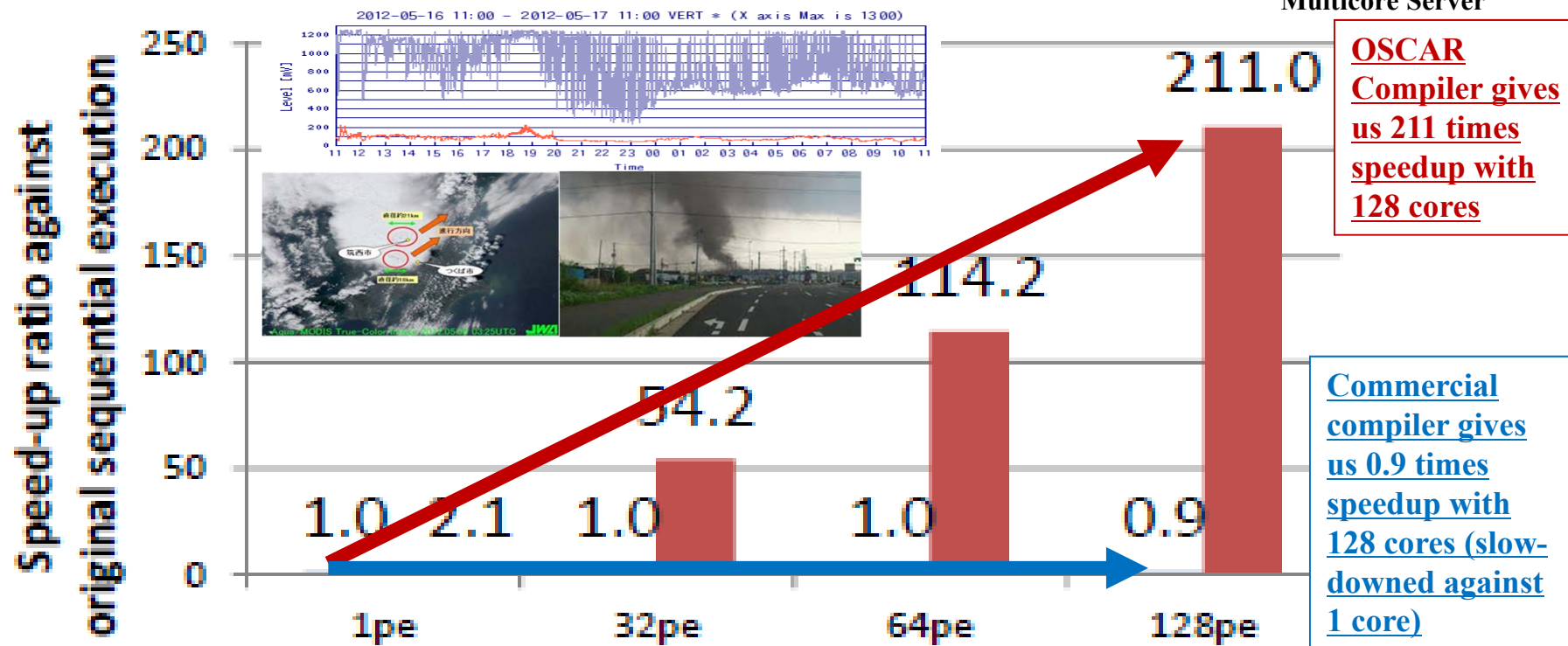

- Automatic parallelizing compiler available on the market gave us no speedup against execution time on 1 core on 64 cores
 - Execution time with 128 cores was slower than 1 core (0.9 times speedup)
- Advanced OSCAR parallelizing compiler gave us 211 times speedup with 128cores against execution time with 1 core using commercial compiler
 - OSCAR compiler gave us 2.1 times speedup on 1 core against commercial compiler by global cache optimization

1987 OSCAR(Optimally Scheduled Advanced Multiprocessor)

Co-design of Compiler and Architecture

Looking at various applications, design a parallelizing compiler and design a multiprocessor/multicore-processor to support compiler optimization

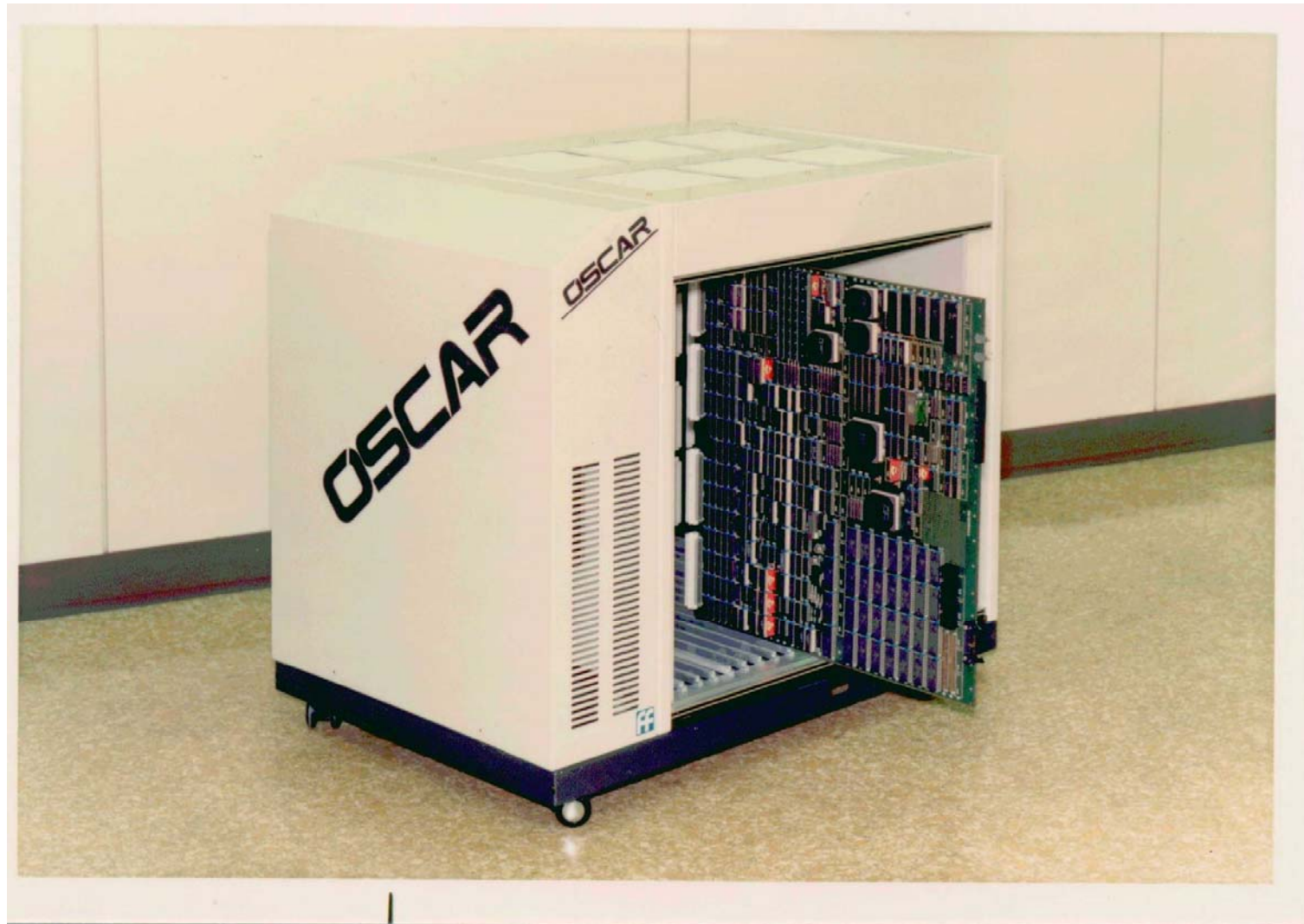

NWT



Machine Cycle Time	9.5ns (105MHz)
PE Performance	1.68GFlops
PE Memory Size	256MB/PE
Crossbar Bandwidth	4B/cycle x 2 (send/receive simultaneous)/PE = 421MB/s x 2 /PE
Number of PEs	140PEs + 2Control Proc.

NAL computer center, Chofu, Tokyo, Feb. 1, 1993

Earth Simulator

(<http://www.es.jamstec.go.jp/>)

- Earth Environmental simulation like Global Warming, El Nino, Plate Movement for the all lives onr this planet.
- Developed in Mar. 2002 by STA (MEXT) and NEC with 400 M\$ investment under Dr. Miyoshi's direction.

(Dr.Miyoshi: Passed away in Nov.2001. NWT, VPP500, SX6)



Mr. Hajime Miyoshi

Image of Earth Simulator

4 Tennis Courts

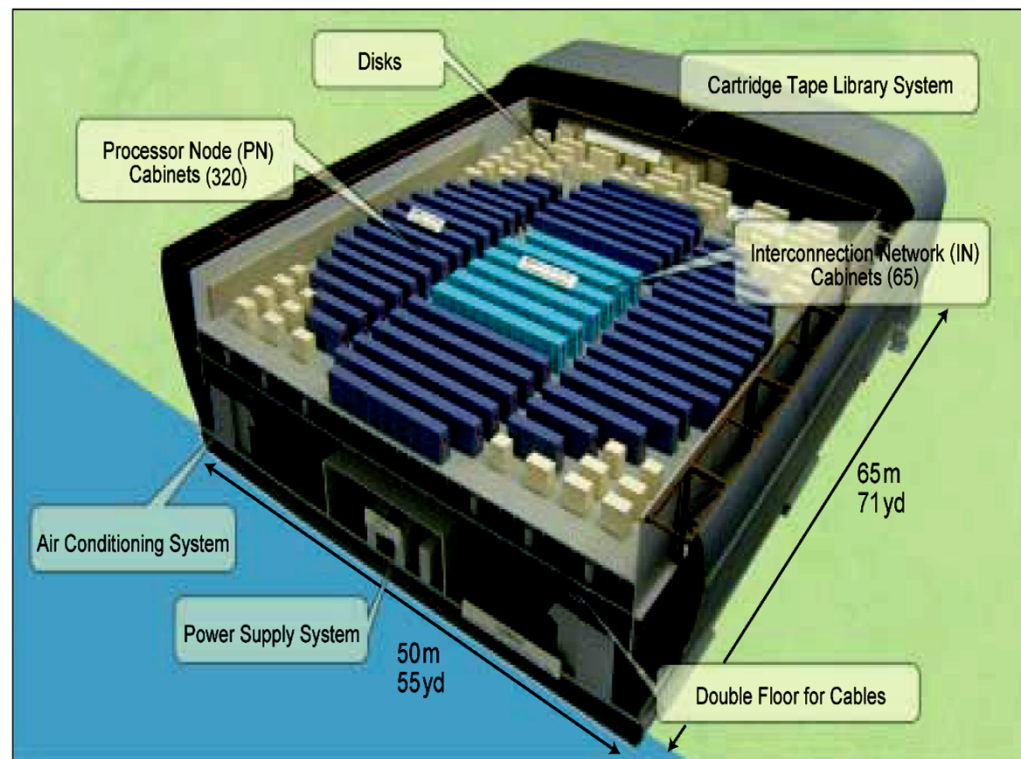

40 TFLOPS Peak ($40 \cdot 10^{12}$)

35.6 TFLOPS Linpack

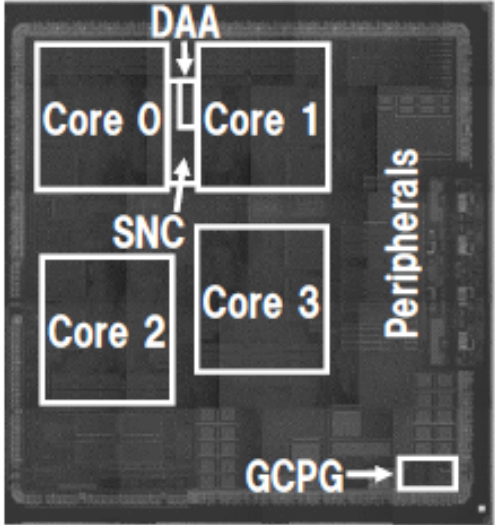
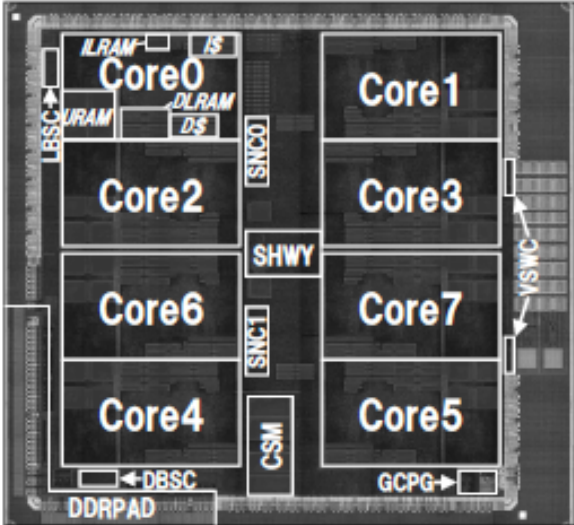
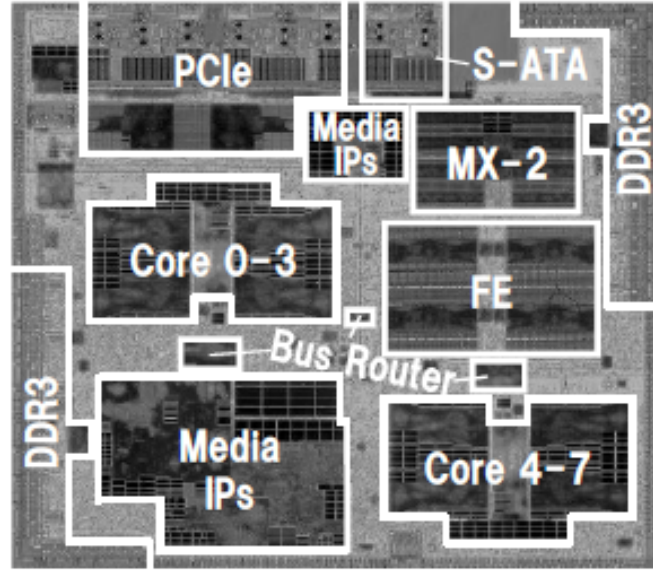

4 core multicore RP1 (2007) , 8 core multicore RP2 (2008) and 15 core Heterogeneous multicore RPX (2010) developed in NEDO Projects with Hitachi and Renesas

RP-1 (ISSCC2007 #5.3)	RP-2 (ISSCC2008 #4.5)	RP-X (ISSCC2010 #5.3)
		
90nm, 8-layer, triple-Vth, CMOS	90nm, 8-layer, triple-Vth, CMOS	45nm, 8-layer, triple-Vth, CMOS
97.6 mm ² (9.88 x 9.88 mm)	104.8 mm ² (10.61 x 9.88 mm)	153.8 mm ² (12.4 x 12.4 mm)
1.0V (internal), 1.8/3.3V (I/O)	1.0-1.4V (internal), 1.8/3.3V (I/O)	1.0-1.2V (internal), 1.2-3.3V (I/O)
600MHz ,4.32 GIPS,16.8 GFLOPS	600MHz , 8.64 GIPS, 33.6 GFLOPS	648MHz, 13.7GIPS, 115GOPS, 36.2GFLOPS
11.4 GOPS/W (32b換算)	18.3 GOPS/W (32b換算)	37.3 GOPS/W (32b換算)

Power Reduction of MPEG2 Decoding to 1/4 on 8 Core Homogeneous Multicore RP-2 by OSCAR Parallelizing Compiler

MPEG2 Decoding with 8 CPU cores

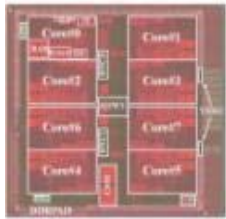

Without Power Control
(Voltage : 1.4V)

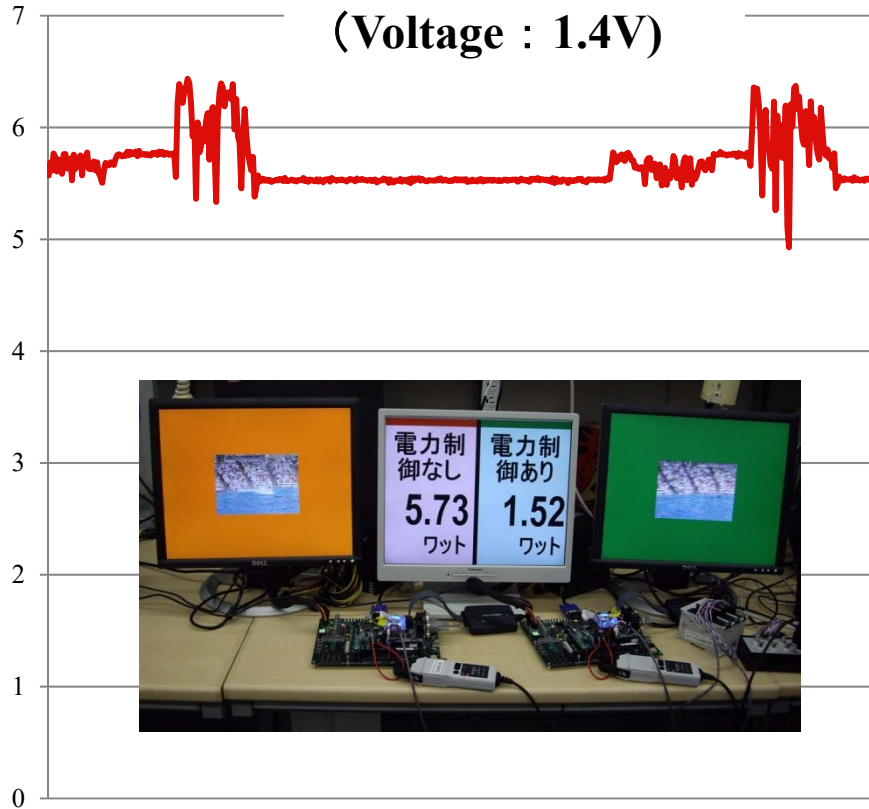

Avg. Power
5.73 [W]

With Power Control
(Frequency,
Resume Standby:
Power shutdown &
Voltage lowering 1.4V-1.0V)

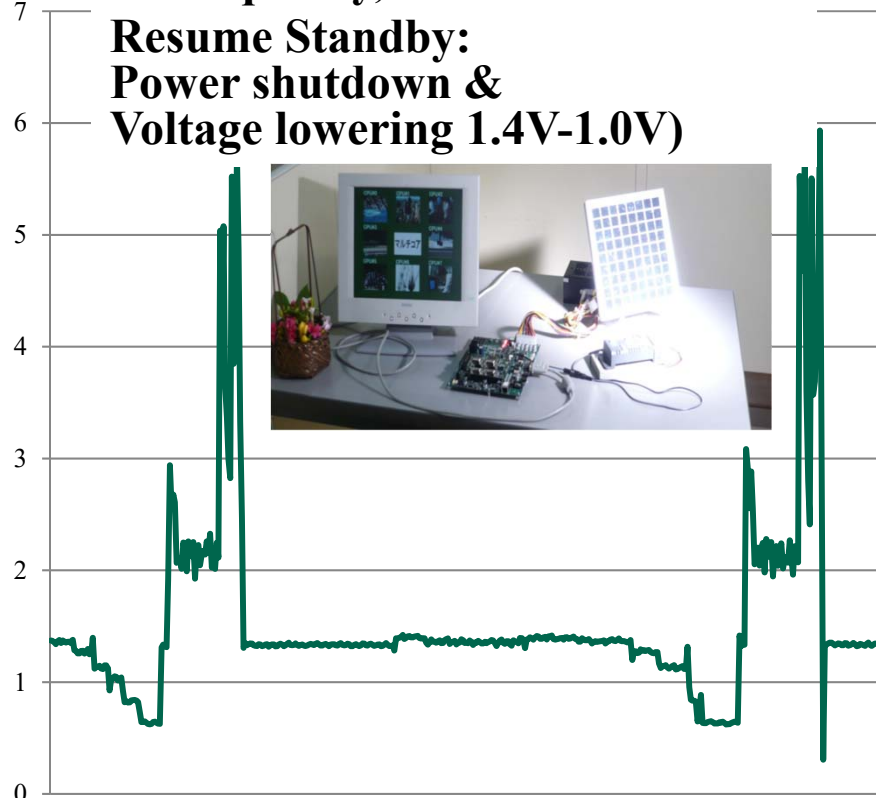

Avg. Power
1.52 [W]

73.5% Power Reduction



Demo of NEDO Multicore for Real Time Consumer Electronics at the Council of Science and Engineering Policy on April 10, 2008

第74回総合科学技術会議【平成20年4月10日】



第74回総合科学技術会議の様子(1)



第74回総合科学技術会議の様子(2)



第74回総合科学技術会議の様子(3)



第74回総合科学技術会議の様子(4)

CSTP Members

Prime Minister:

Mr. Y. FUKUDA

**Minister of State for
Science, Technology
and Innovation
Policy:**

Mr. F. KISHIDA

**Chief Cabinet
Secretary:**

Mr. N. MACHIMURA

**Minister of Internal
Affairs and
Communications :**

Mr. H. MASUDA

Minister of Finance :

Mr. F. NUKAGA

Minister of

**Education, Culture,
Sports, Science and
Technology:**

Mr. K. TOKAI

**Minister of
Economy, Trade and
Industry:**

Mr. A. AMARI

Green Computing Systems R&D Center

Waseda University

Supported by METI (Mar. 2011 Completion)

<R & D Target>

Hardware, Software, Application
for Super Low-Power Manycore

- More than 64 cores
- Natural air cooling (No fan)
Cool, Compact, Clear, Quiet
- Operational by Solar Panel

<Industry, Government, Academia>

Hitachi, Fujitsu, NEC, Renesas, Olympus,
Toyota, Denso, Mitsubishi, Toshiba,
OSCAR Technology, etc

<Ripple Effect>

- Low CO₂ (Carbon Dioxide) Emissions
- Creation Value Added Products
- Automobiles, Medical, IoT, Servers

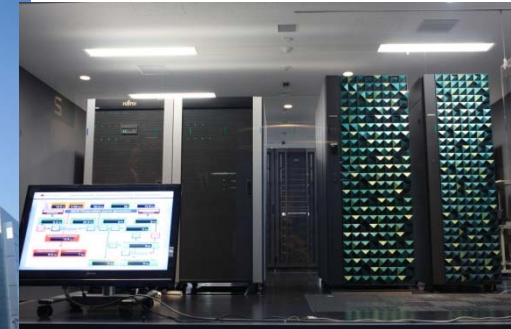

Hitachi SR16000:

Power7 128coreSMP

Fujitsu M9000

SPARC VII 256 core SMP



Beside Subway Waseda Station,
Near Waseda Univ. Main Campus

OSCAR Parallelizing Compiler

To improve **effective performance, cost-performance and software productivity and reduce power**

Multigrain Parallelization (LCPC1991,2001,04)
coarse-grain parallelism among loops and subroutines (2000 on SMP), near fine grain parallelism among statements (1992) in addition to loop parallelism

Data Localization

Automatic data management for distributed shared memory, cache and local memory (Local Memory 1995, 2016 on RP2, Cache2001,03)
Software Coherent Control (2017)

Data Transfer Overlapping (2016 partially)

Data transfer overlapping using Data Transfer Controllers (DMAs)

Power Reduction

(2005 for Multicore, 2011 Multi-processes, 2013 on ARM)
Reduction of consumed power by compiler control DVFS and Power gating with hardware supports.

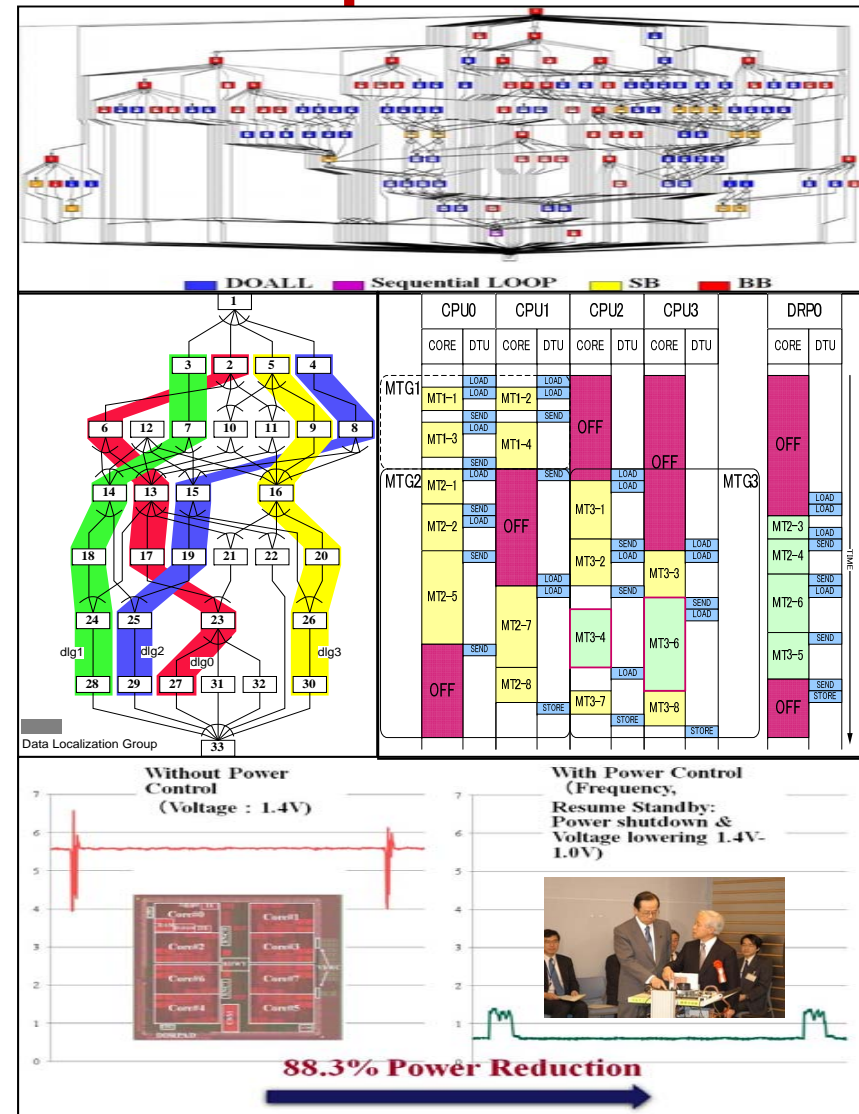

MTG of Su2cor-LOOPS-DO400

- **Coarse grain parallelism PARA_ALD = 4.3**

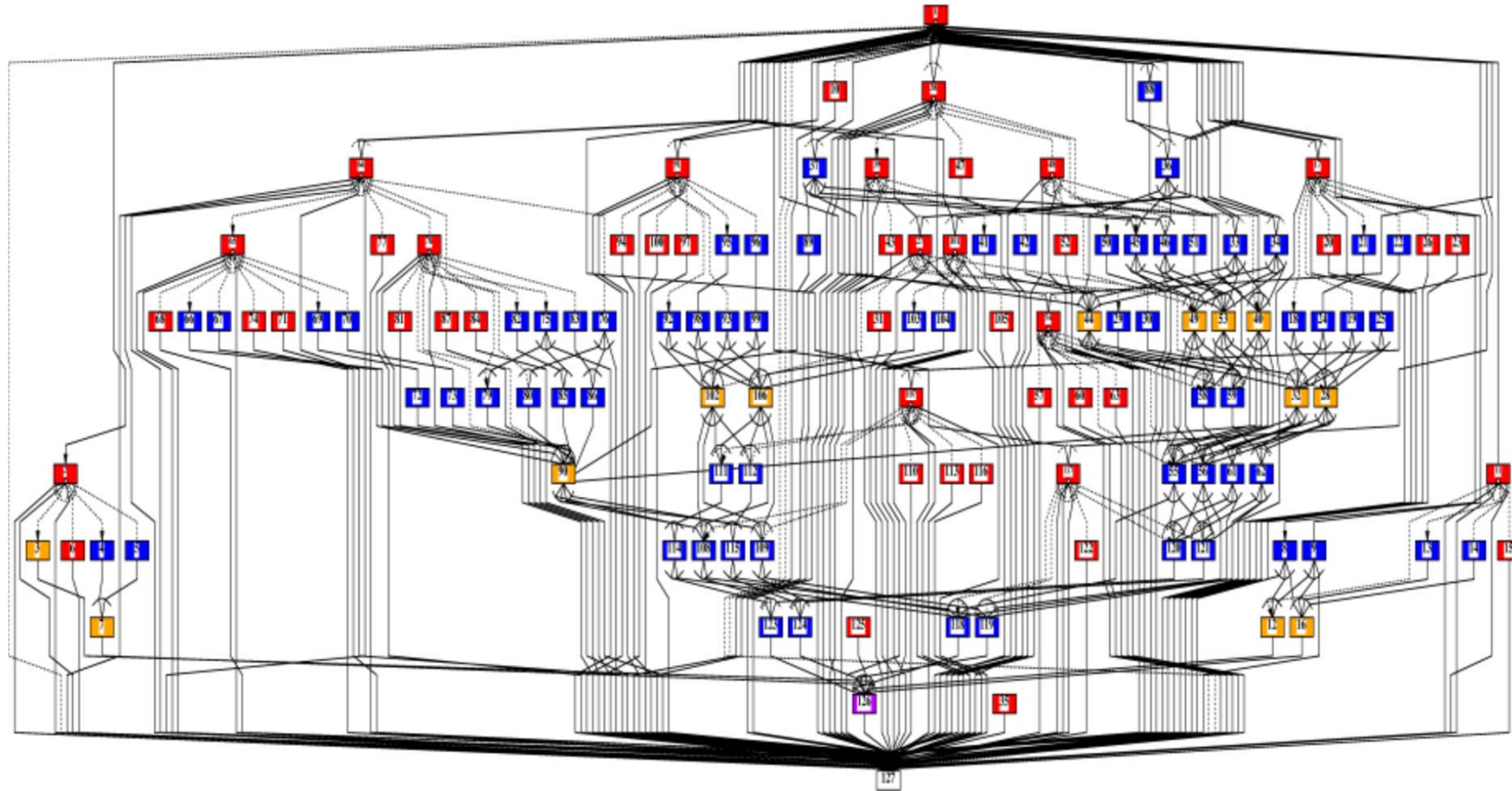

■ DOALL ■ Sequential LOOP ■ SB ■ BB

Data Localization

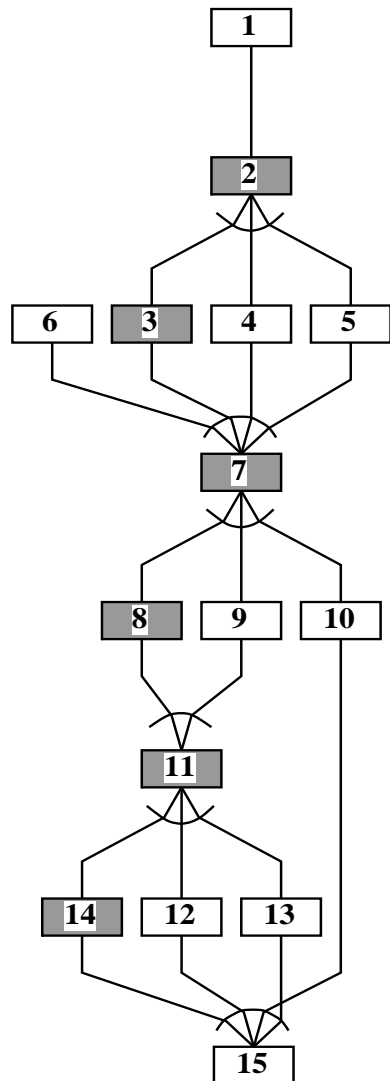

MTG

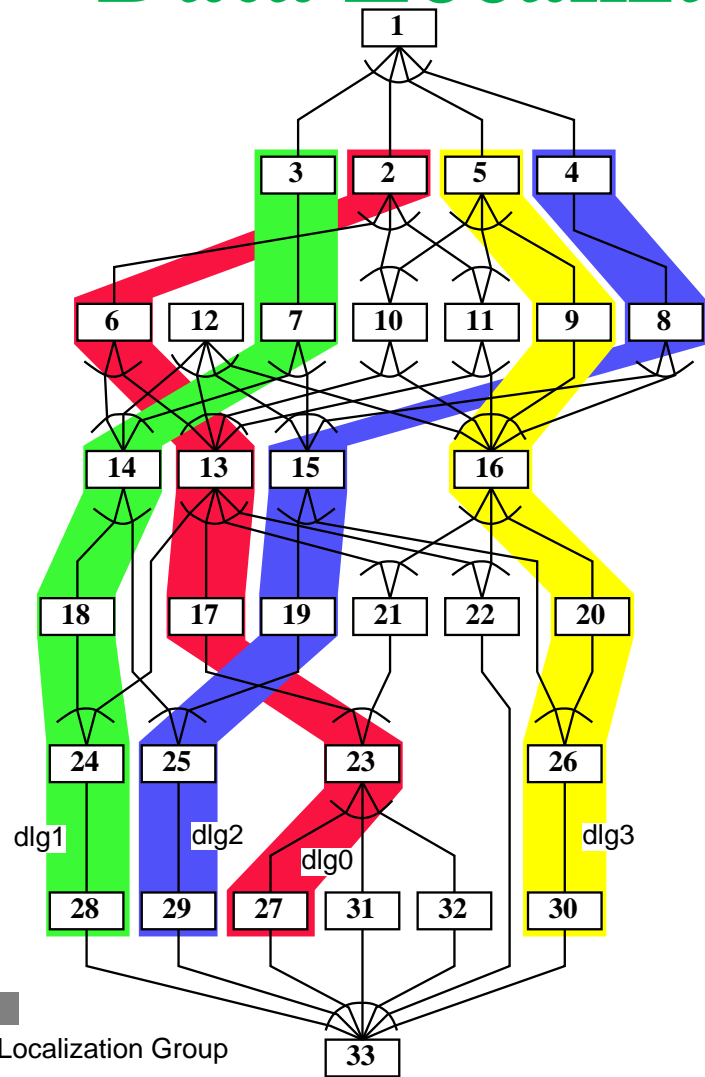

MTG after Division

■ Data Localization Group

PE0	PE1
12	1
2	3
6	7
4	14
8	18
15	5
19	9
25	11
29	10
13	16
17	20
22	26
21	30
23	24
27	28
	32
	31

A schedule for two processors

Multicore Program Development Using OSCAR API V2.0

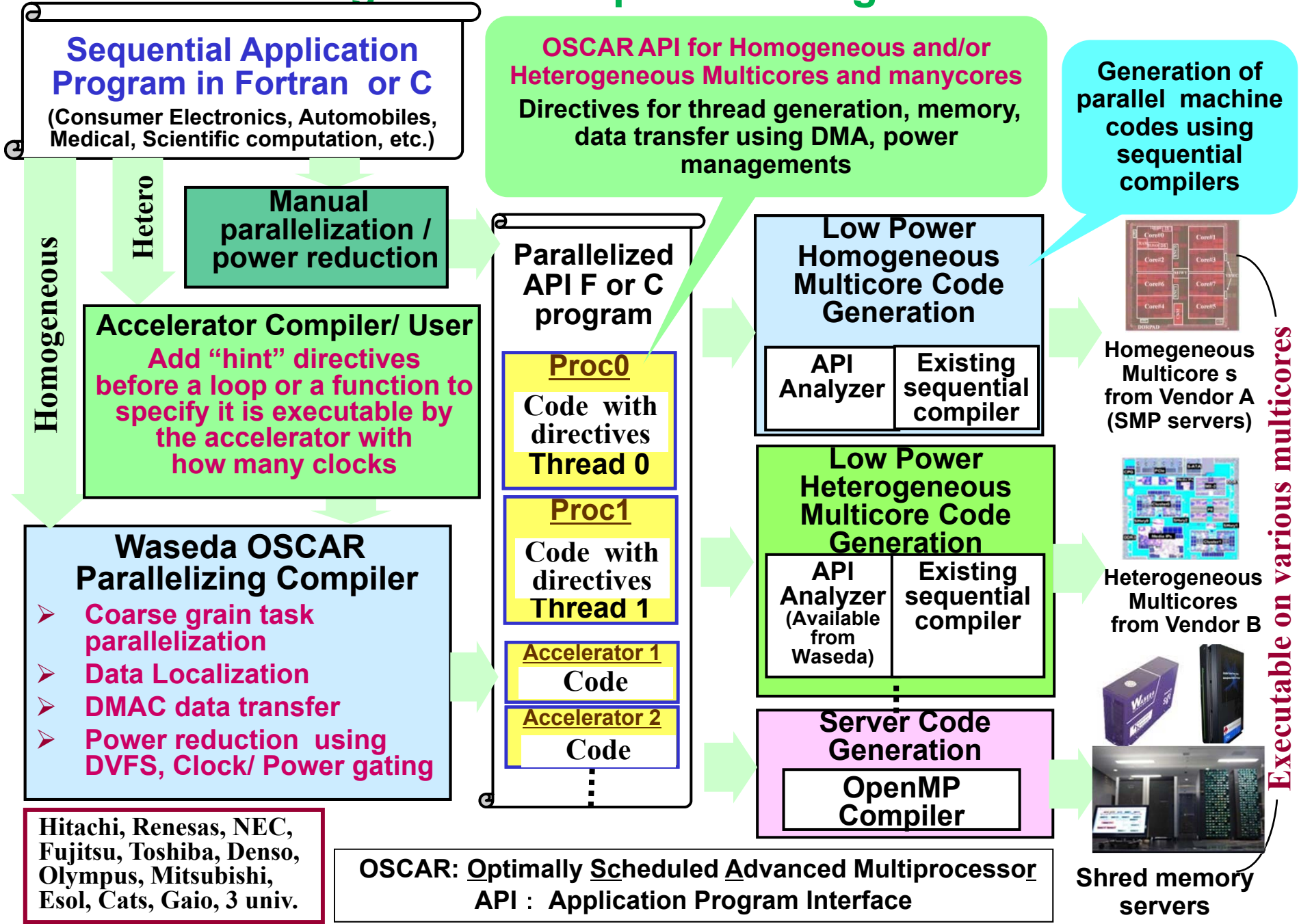

110 Times Speedup against the Sequential Processing for GMS Earthquake Wave Propagation Simulation on Hitachi SR16000

(Power7 Based 128 Core Linux SMP) [\(LCPC2015\)](#)

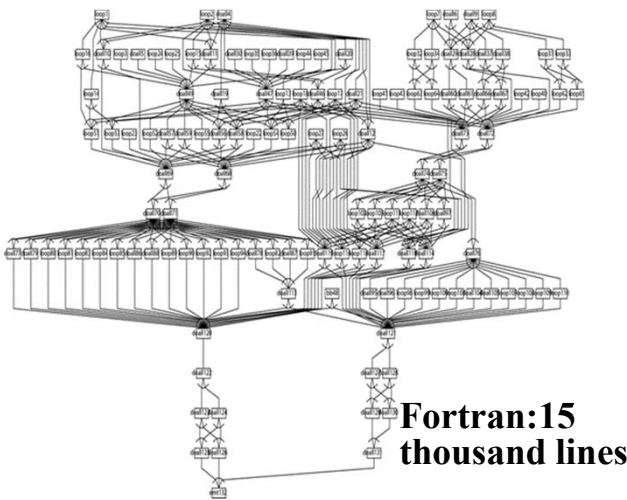
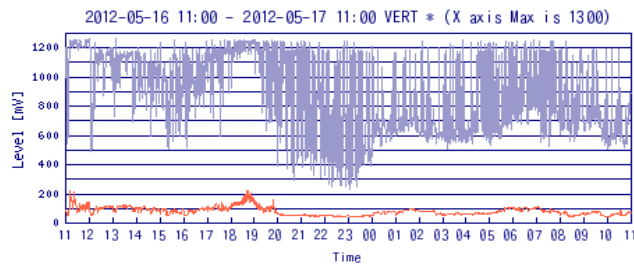

First touch for distributed shared memory and cache optimization over loops are important for scalable speedup

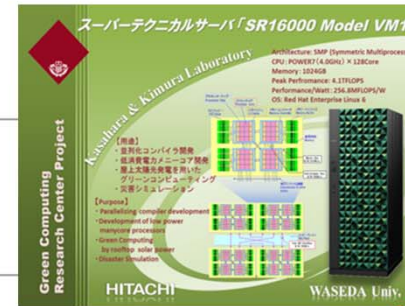
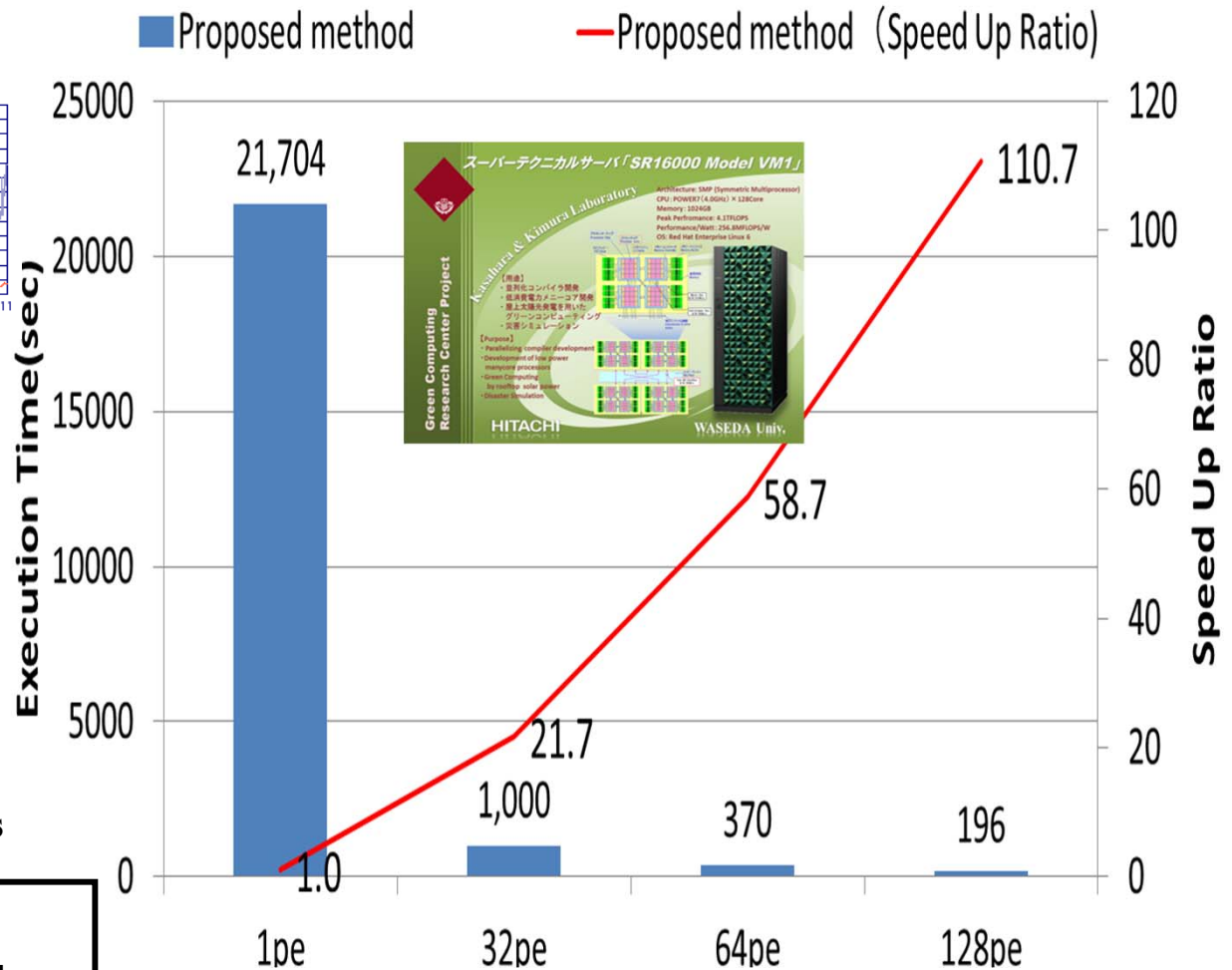

Performance on Multicore Server for Latest Cancer Treatment Using Heavy Particle (Proton, Carbon Ion)

327 times speedup on 144 cores

Hitachi 144cores SMP Blade Server BS500:
Xeon E7-8890 V3(2.5GHz 18core/chip) x8 chip

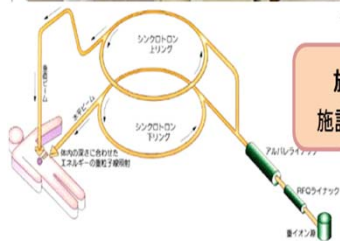

放射線医学研究所
施設の費用: 120億円

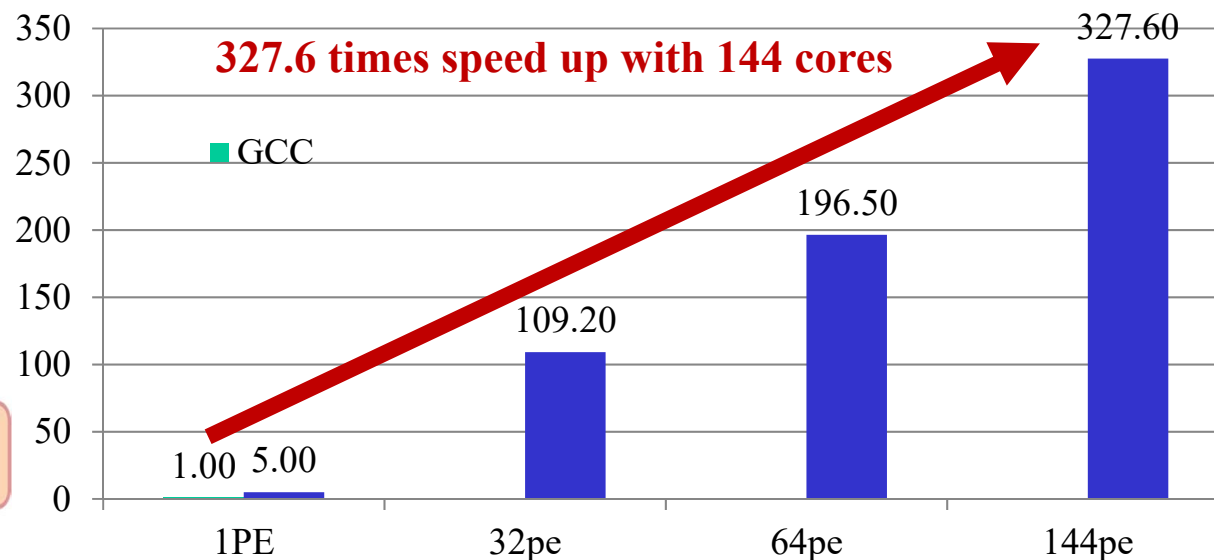

- Original **sequential execution time 2948 sec (50 minutes)** using GCC was reduced to **9 sec with 144 cores** (327.6 times speedup)
- Reduction of treatment cost and reservation waiting period is expected

Parallelization of 3D-FFT for New Magnetic Material Computation on Hitachi SR16000 Power7 CC-Numa Server

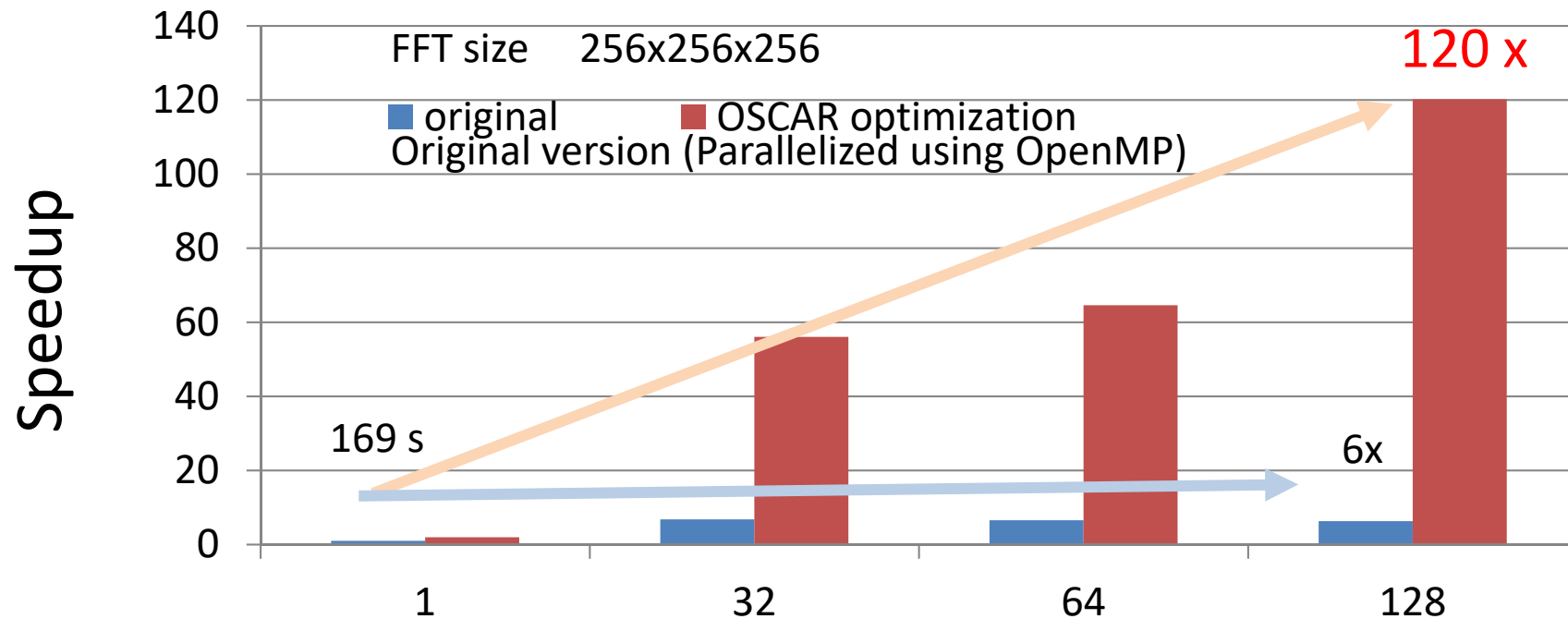

OSCAR optimization

- reducing number of data transpose with interchange, code motion and loop fusion



Engine Control by multicore with Denso

Though so far parallel processing of the engine control on multicore has been very difficult, Denso and Waseda succeeded 1.95 times speedup on 2core V850 multicore processor.



- Hard real-time automobile engine control by multicore using local memories
- Millions of lines C codes consisting conditional branches and basic blocks

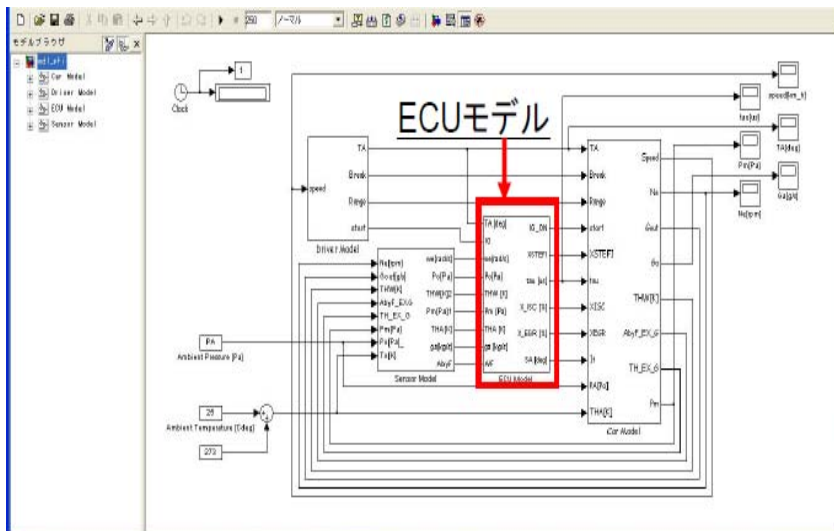
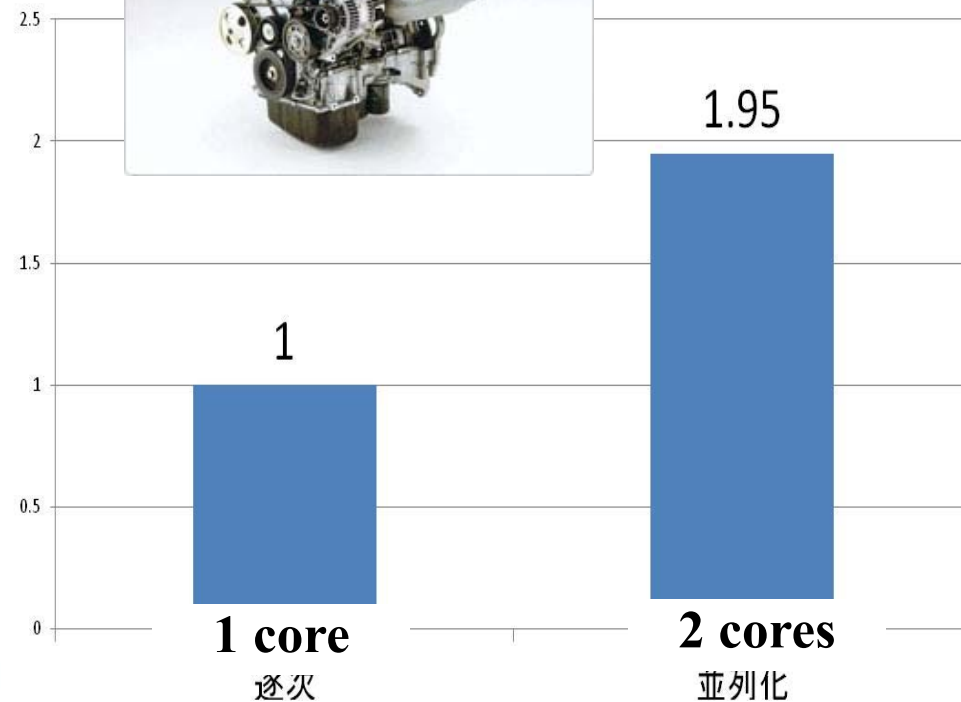

OSCAR Compile Flow for Simulink Applications

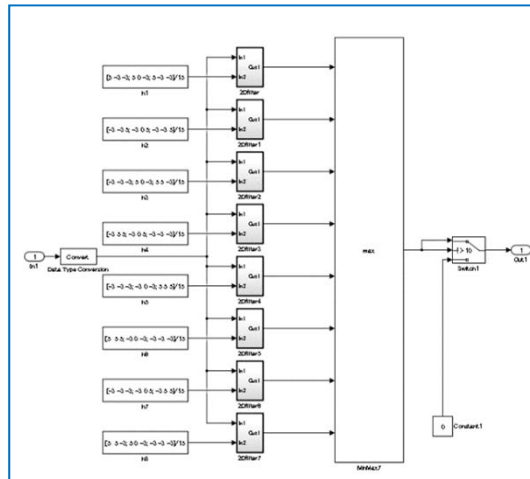

Simulink model

Generate C code
using Embedded Coder

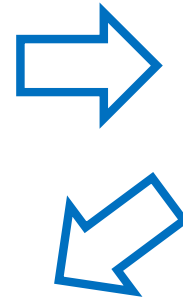

```

/* Model step function */
void VesselExtraction_step(void)
{
    int32_T i;
    real_T u0;

    /* DataTypeConversion: '<S1>/Data Type Conversion' incorporates:
     * Import: '<Root>/In1'
     */
    for (i = 0; i < 16384; i++) {
        VesselExtraction_B.DataTypeConversion[i] = VesselExtraction_U.In1[i];
    }

    /* End of DataTypeConversion: '<S1>/Data Type Conversion' */

    /* Outputs for Atomic SubSystem: '<S1>/2Dfilter' */

    /* Constant: '<S1>/h1' */
    VesselExtraction_Dfilter(VesselExtraction_B.DataTypeConversion,
        VesselExtraction_P.h1_Value, &VesselExtraction_B.Dfilter,
        (P_Filter_VesselExtraction_T *)&VesselExtraction_P.Dfilter);

    /* End of Outputs for SubSystem: '<S1>/2Dfilter' */

    /* Outputs for Atomic SubSystem: '<S1>/2Dfilter1' */

    /* Constant: '<S1>/h2' */
    VesselExtraction_Dfilter(VesselExtraction_B.DataTypeConversion,
        VesselExtraction_P.h2_Value, &VesselExtraction_B.Dfilter1,
        (P_Filter_VesselExtraction_T *)&VesselExtraction_P.Dfilter1);
}
    
```

C code

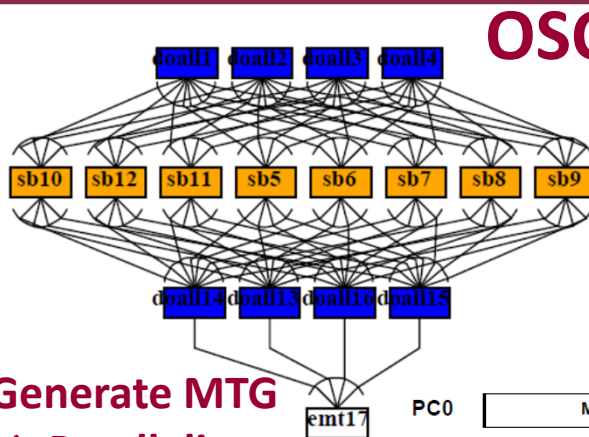

(1) Generate MTG
→ Parallelism

(2) Generate gantt chart
→ Scheduling in a multicore

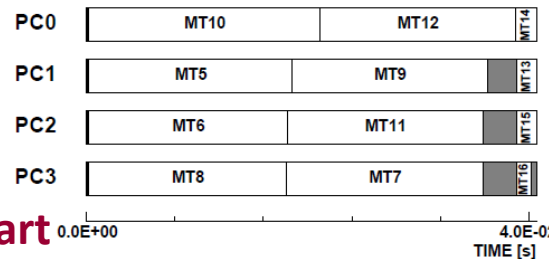

OSCAR Compiler

```

void VesselExtraction_step ( )
{
    int thr1 ;
    int thr2 ;
    int thr3 ;

    oscar_thread_create ( & thr1 ,
        thread_function_001 , (void*)1 ) ;
    oscar_thread_create ( & thr2 ,
        thread_function_002 , (void*)2 ) ;
    oscar_thread_create ( & thr3 ,
        thread_function_003 , (void*)3 ) ;

    VesselExtraction_step_PEO ( ) ;

    oscar_thread_join ( thr1 ) ;
    oscar_thread_join ( thr2 ) ;
    oscar_thread_join ( thr3 ) ;
}
    
```

(3) Generate parallelized C code
using the OSCAR API
→ Multiplatform execution
(Intel, ARM and SH etc)

Speedups of MATLAB/Simulink Image Processing on Various 4core Multicores

(Intel Xeon, ARM Cortex A15 and Renesas SH4A)

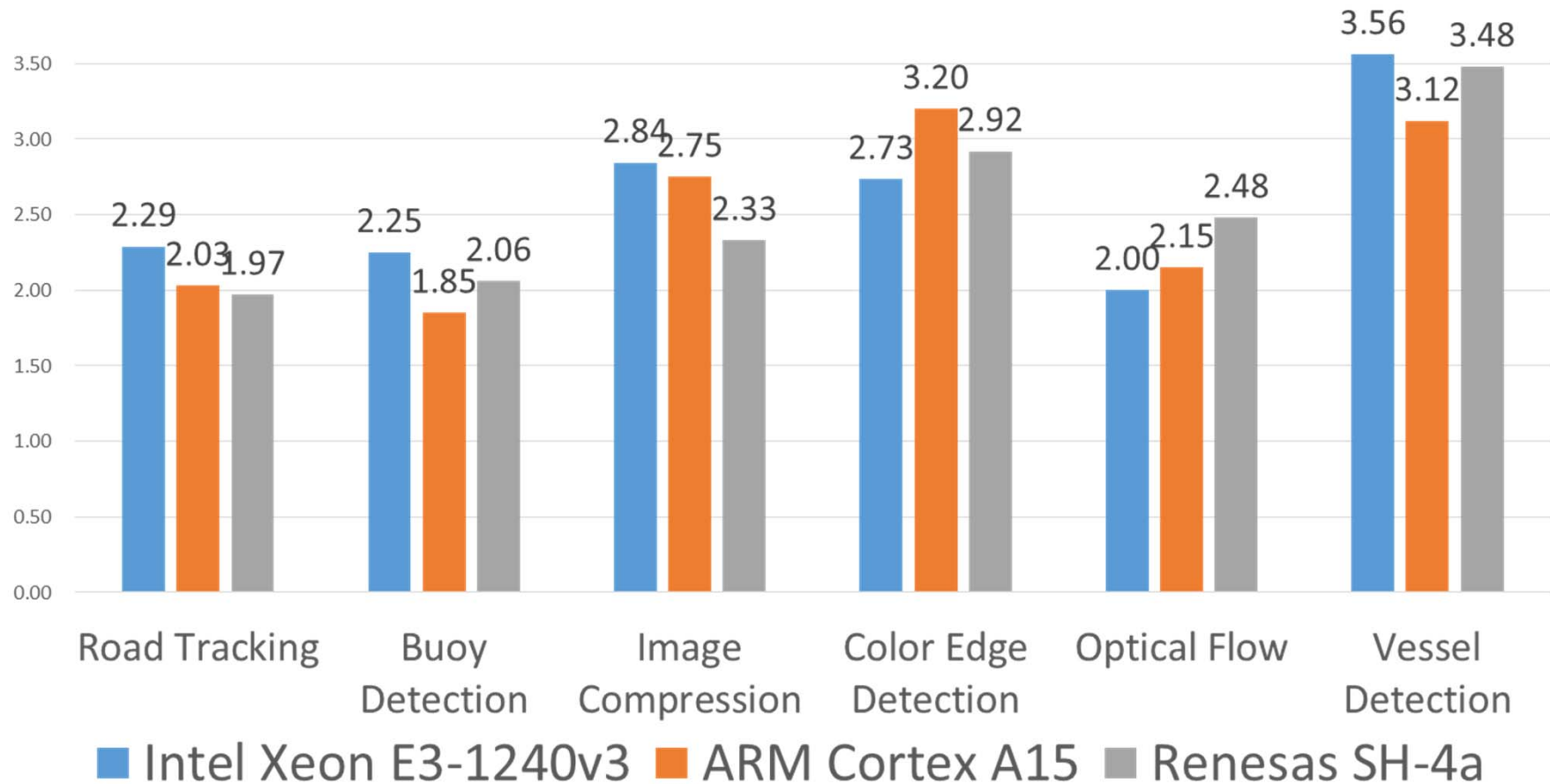

Road Tracking, Image Compression : <http://www.mathworks.co.jp/jp/help/vision/examples>

Buoy Detection : <http://www.mathworks.co.jp/matlabcentral/fileexchange/44706-buoy-detection-using-simulink>

Color Edge Detection : <http://www.mathworks.co.jp/matlabcentral/fileexchange/28114-fast-edges-of-a-color-image--actual-color--not-converting-to-grayscale-/>

Vessel Detection : <http://www.mathworks.co.jp/matlabcentral/fileexchange/24990-retinal-blood-vessel-extraction/>

Low-Power Optimization with OSCAR API

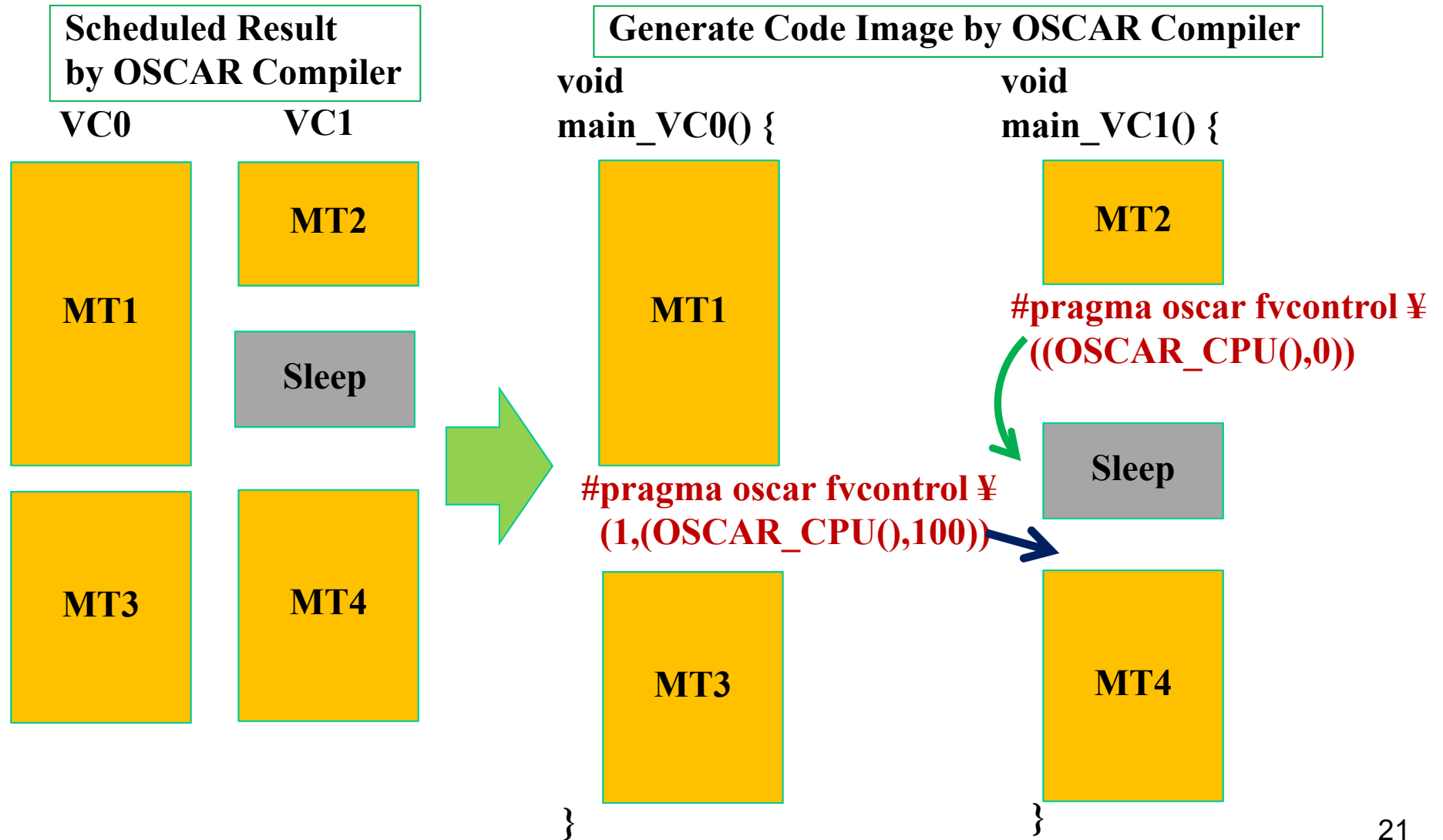

Automatic Power Reduction on ARM CortexA9 with Android

http://www.youtube.com/channel/UCS43INYEIkC8i_KIgfZYQBQ

ODROID X2

Samsung Exynos4412 Prime, ARM Cortex-A9 Quad core
1.7GHz~0.2GHz, used by Samsung's Galaxy S3

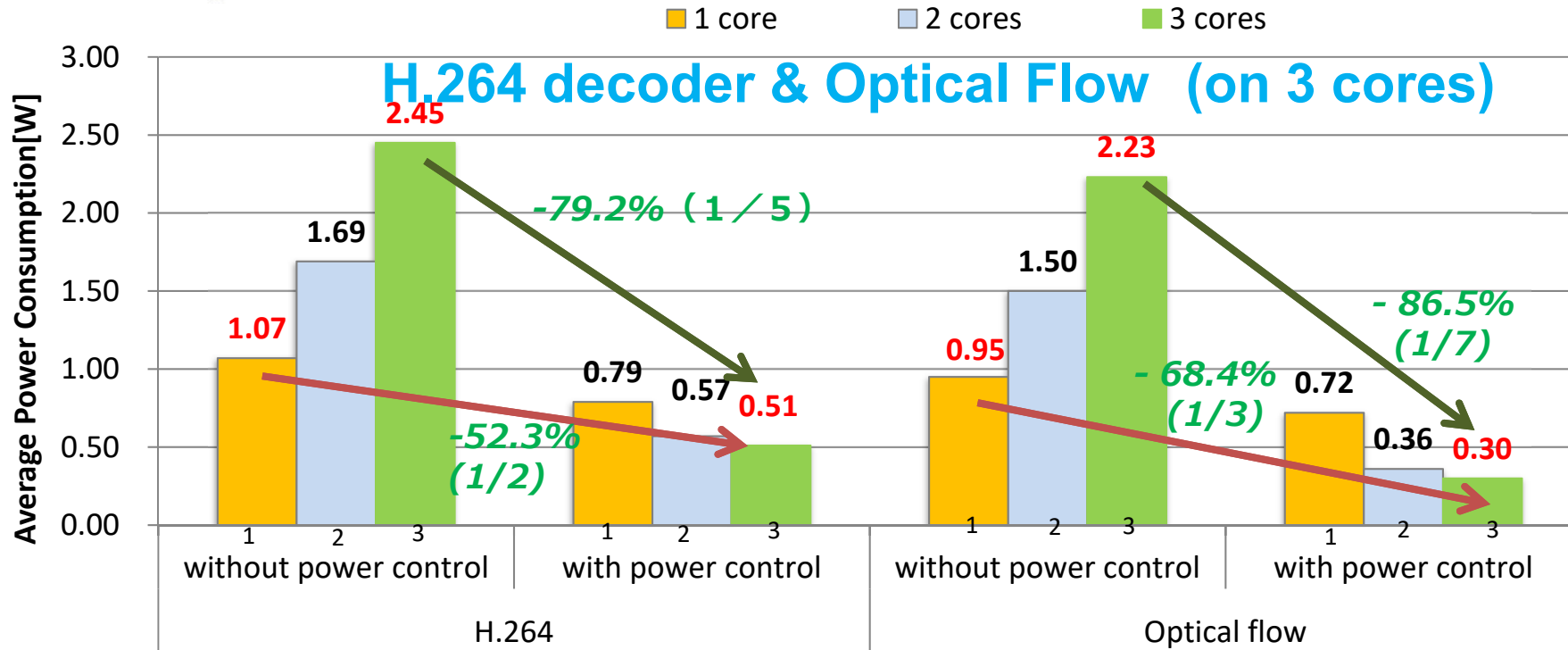
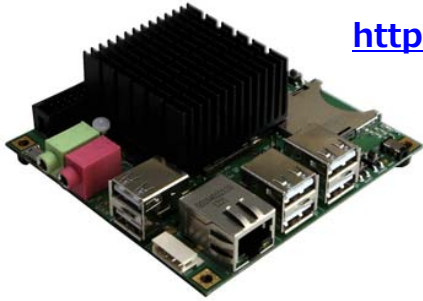

Power for 3cores was reduced to **1/5~1/7** against without software power control
Power for 3cores was reduced to **1/2~1/3** against ordinary 1core execution

Automatic Power Reuction on Intel Haswell

H.264 decoder & Optical Flow (3cores)

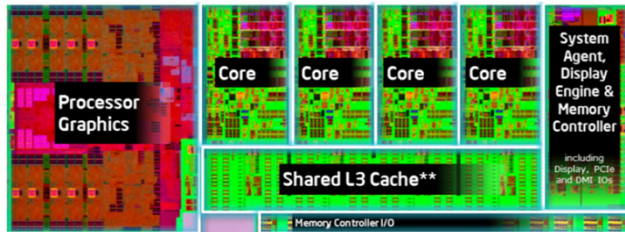

H81M-A, Intel Core i7 4770k
Quad core, 3.5GHz~0.8GHz

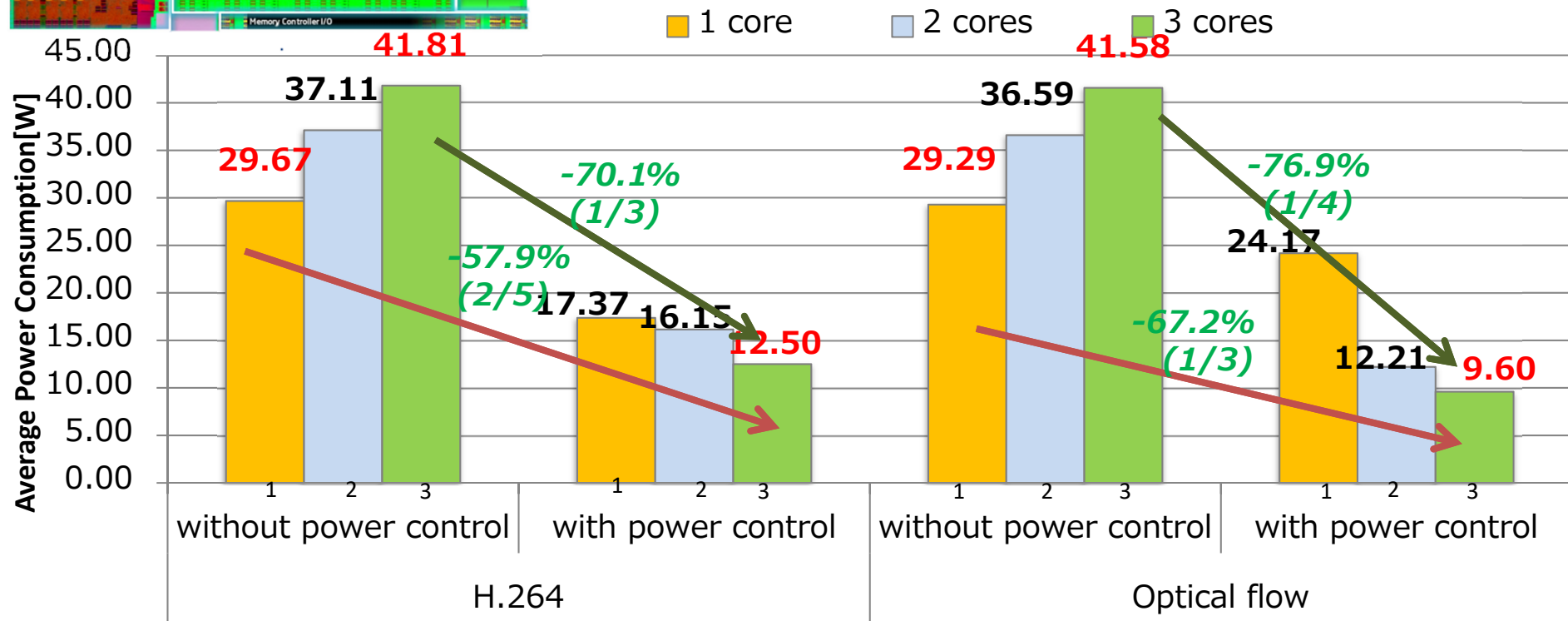

Power for 3cores was reduced to **1/3~1/4** against without software power control

Power for 3cores was reduced to **2/5~1/3** against ordinary 1core execution

An Image of Static Schedule for Heterogeneous Multi-core with Data Transfer Overlapping and Power Control

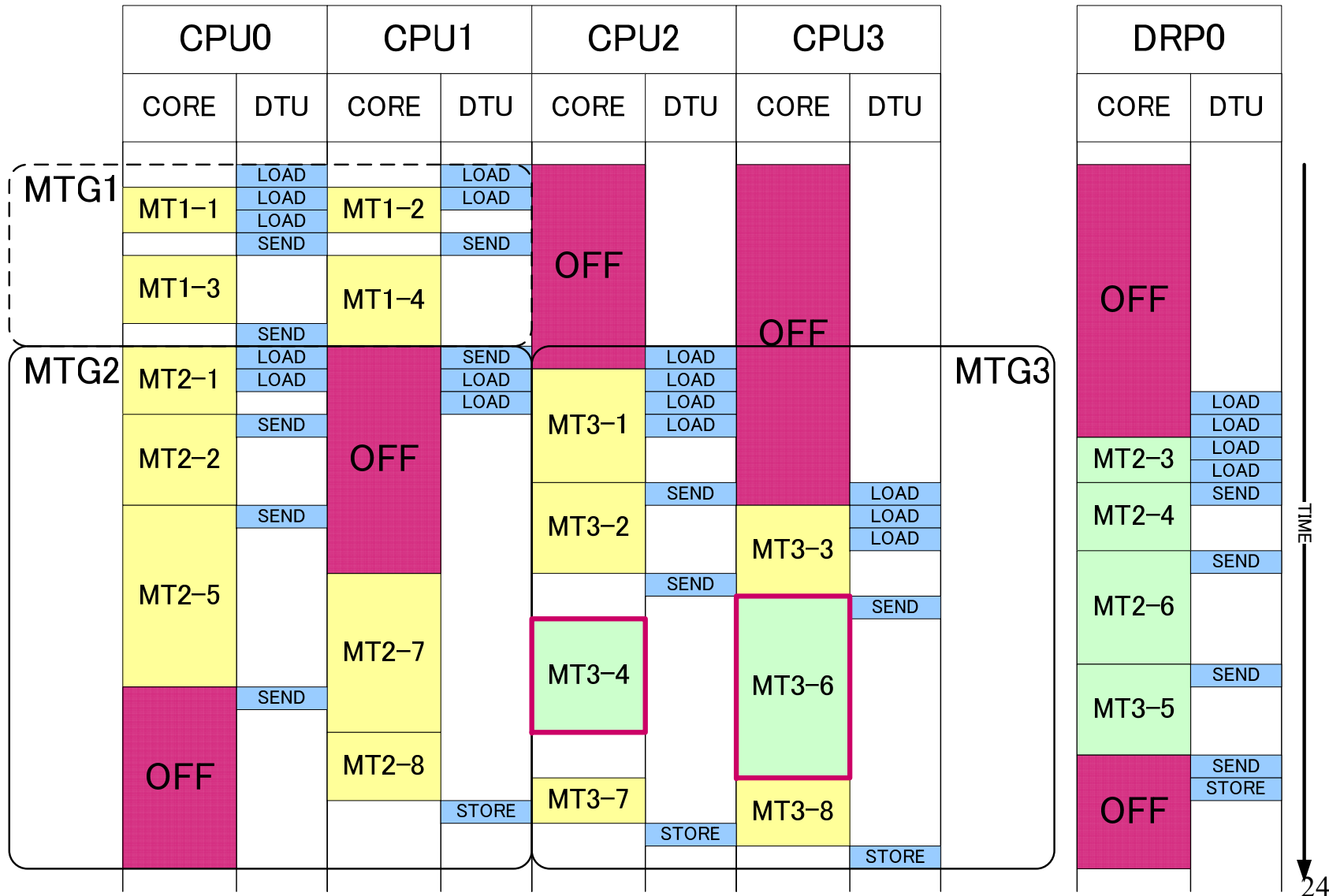

33 Times Speedup Using OSCAR Compiler and OSCAR API on RP-X (Optical Flow with a hand-tuned library)

111[fps]

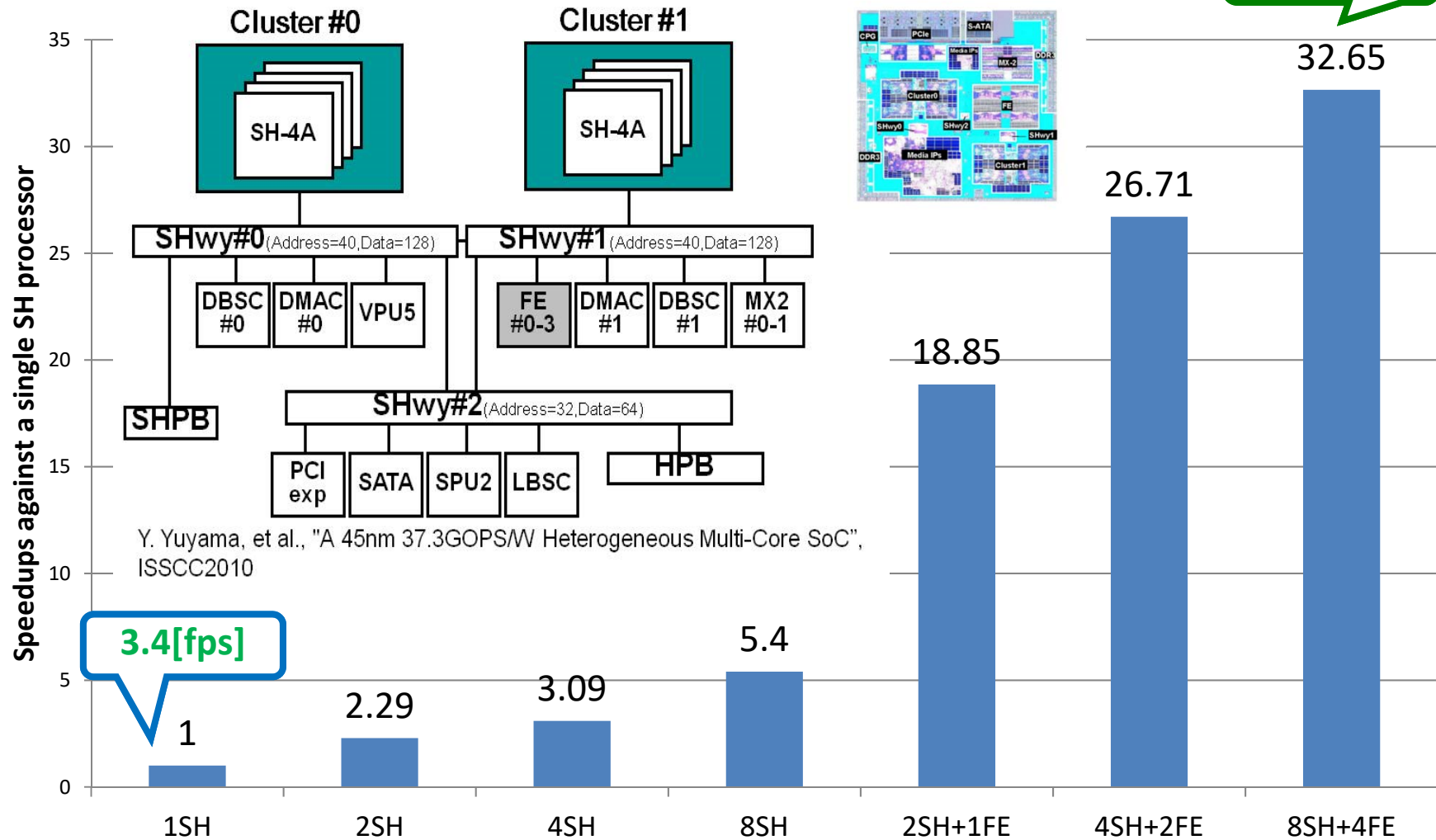

Power Reduction in a real-time execution controlled by OSCAR Compiler and OSCAR API on RP-X (Optical Flow with a hand-tuned library)

Without Power Reduction

With Power Reduction by OSCAR Compiler
70% of power reduction

Average: 1.76[W]



Average: 0.54[W]

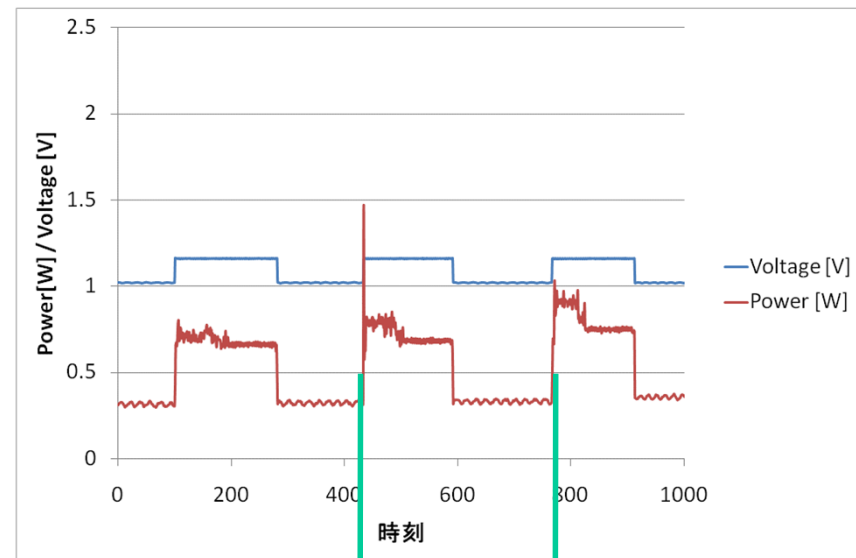
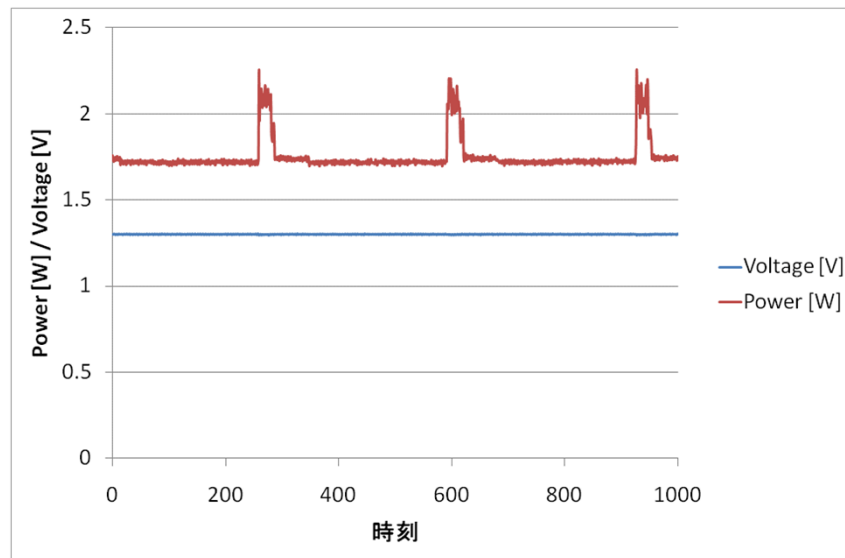

**1cycle : 33[ms]
→30[fps]**

Automatic Parallelization of JPEG-XR for Drinkable Inner Camera (Endo Capsule)

10 times more speedup needed after parallelization for 128 cores of Power 7. Less than 35mW power consumption is required.

- TILEPro64

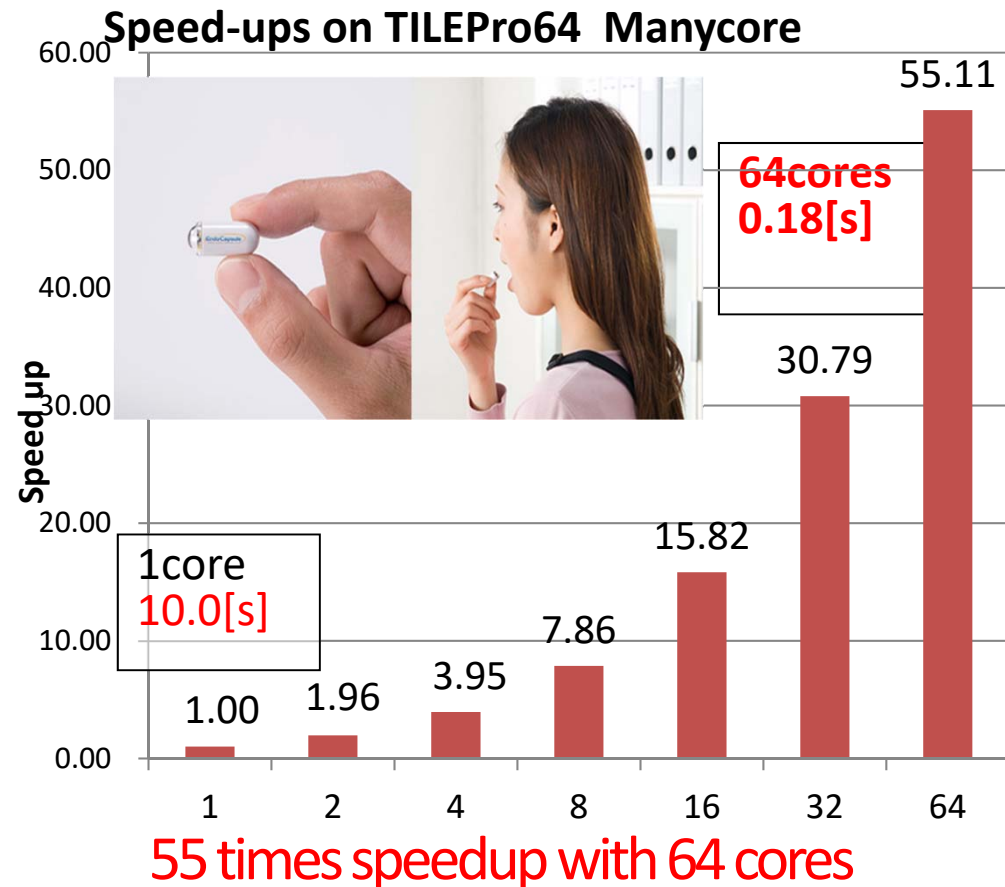
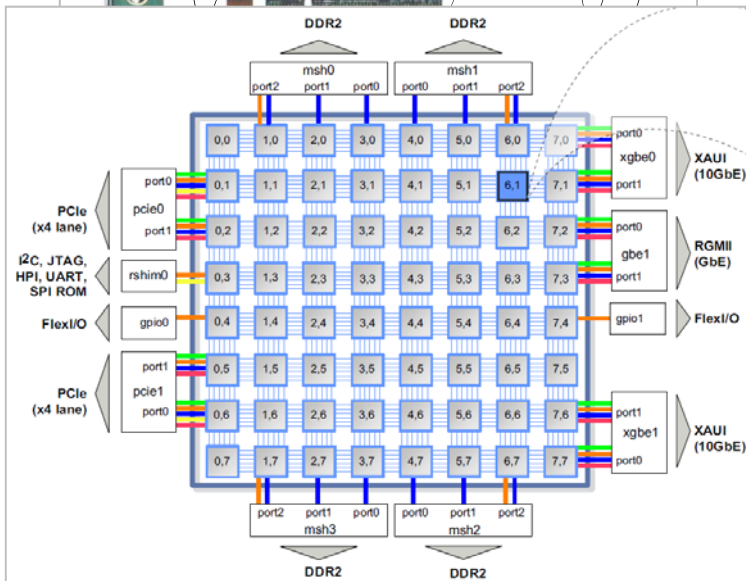

OSCAR Vector Multicore and Compiler for Embedded to Servers with OSCAR Technology

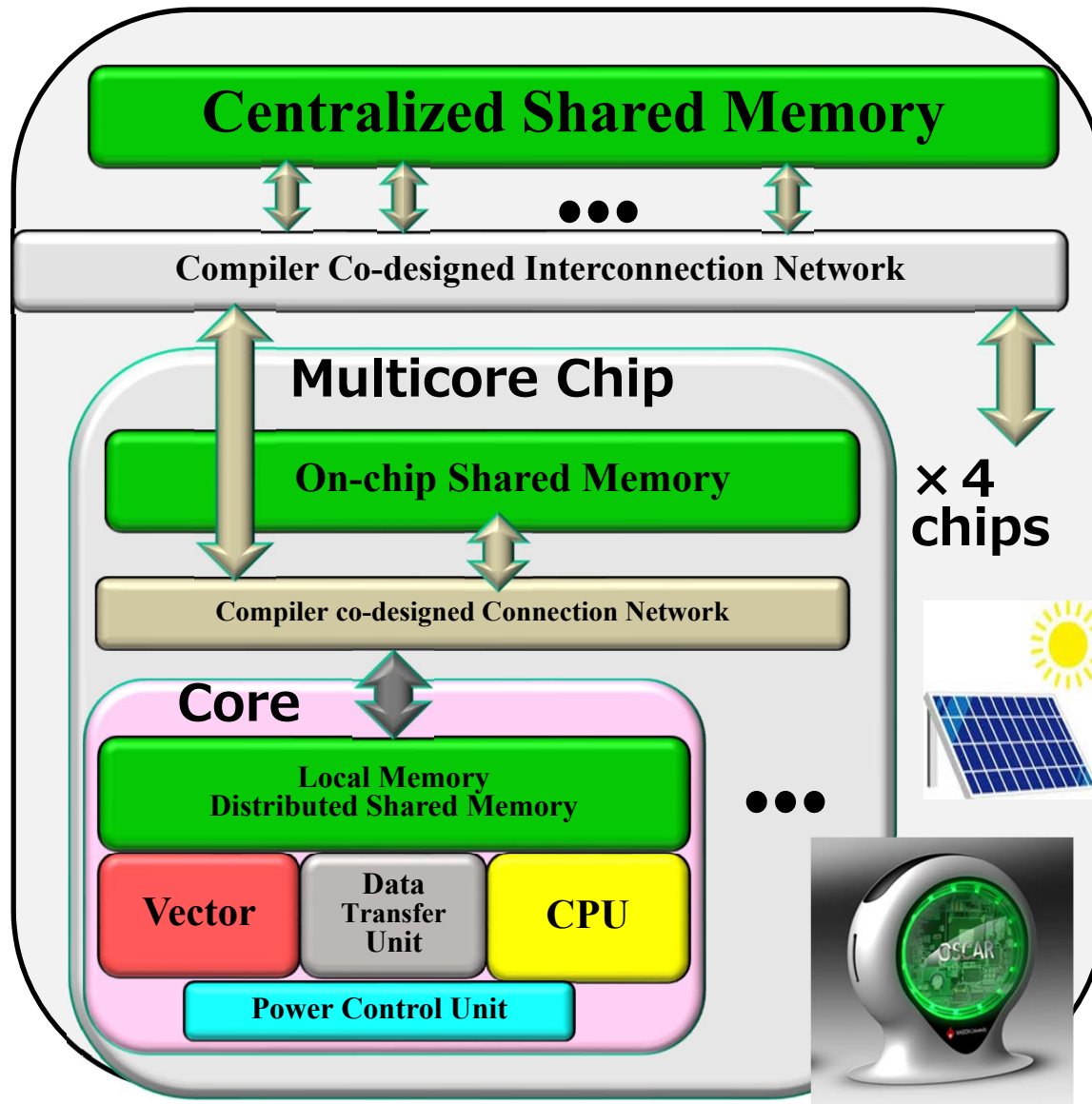

Target:

- Solar Powered
- Compiler power reduction.
- Fully automatic parallelization and vectorization including local memory management and data transfer.

Vector Accelerator

Features

- Attachable for any CPUs (Intel, ARM, IBM)
- Data driven initiation by sync flags

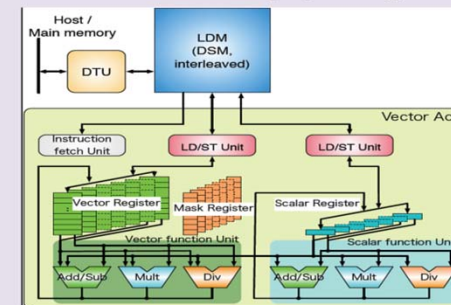

Function Units [tentative]

- Vector Function Unit
 - 8 double precision ops/clock
 - 64 characters ops/clock
 - Variable vector register length
 - Chaining LD/ST & Vector pipes
- Scalar Function Unit

Registers[tentative]

- Vector Register 256Bytes/entry, 32entry
- Scalar Register 8Bytes/entry
- Floating Point Register 8Bytes/entry
- Mask Register 32Bytes/entry

OSCAR Technology Corp.

Started up on Feb. 28, 2013:

Licensing the all patents and OSCAR compiler from Waseda Univ.

Founder and CEO: Dr. T. Ono (Ex- CEO of First Section-listed Company, Director of National U., Invited Prof. of Waseda U.)

Executives: **Dr. M. Ohashi : COO** (Ex- OO of Ono Sokki)

Mr. A. Nodomi : CTO (Ex- Spansion)

Mr. N. Ito (Ex- Visiting Prof. Tokyo Agricult. And Tech. U.)

Dr. K. Shirai (Ex- President of Waseda U., Ex- Chairman of Japanese Open U.)

Mr. K. Ashida (Ex- VP Sumitomo Trading, Adhida Consult. CEO)

Mr. S. Tsuchida (Co-Chief Investment Officer of Innovation Network Corp. of Japan)

Auditor: **Mr. S. Honda** (Ex- Senior VP and General Manager of MUFG)

Dr. S. Matuda (Emeritus Prof. of Waseda U., Chairman of WERU INVESTMENT)

Mr. Y. Hirowatari (President of AGS Consulting)

Advisors: **Prof. H. Kasahara** (Waseda U.)

Prof. K. Kimura (Waseda U.)



富士通ベクトルスパコンVPP5000

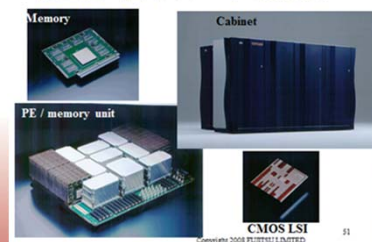

OSCAR TECHNOLOGY CORPORATION

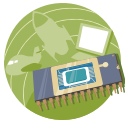

Future Multicore Products with Automatic Parallelizing Compiler



Next Generation Automobiles

- Safer, more comfortable, energy efficient, environment friendly
- Cameras, radar, car2car communication, internet information integrated brake, steering, engine, moter control

Smart phones



- From everyday recharging to less than once a week
- Solar powered operation in emergency condition
- Keep health

Advanced medical systems



Cancer treatment, Drinkable inner camera

- Emergency solar powered
- No cooling fun, No dust , clean usable inside OP room



Personal / Regional Supercomputers



Solar powered with more than 100 times power efficient : FLOPS/W

- Regional Disaster Simulators saving lives from tornadoes, localized heavy rain, fires with earth quakes